

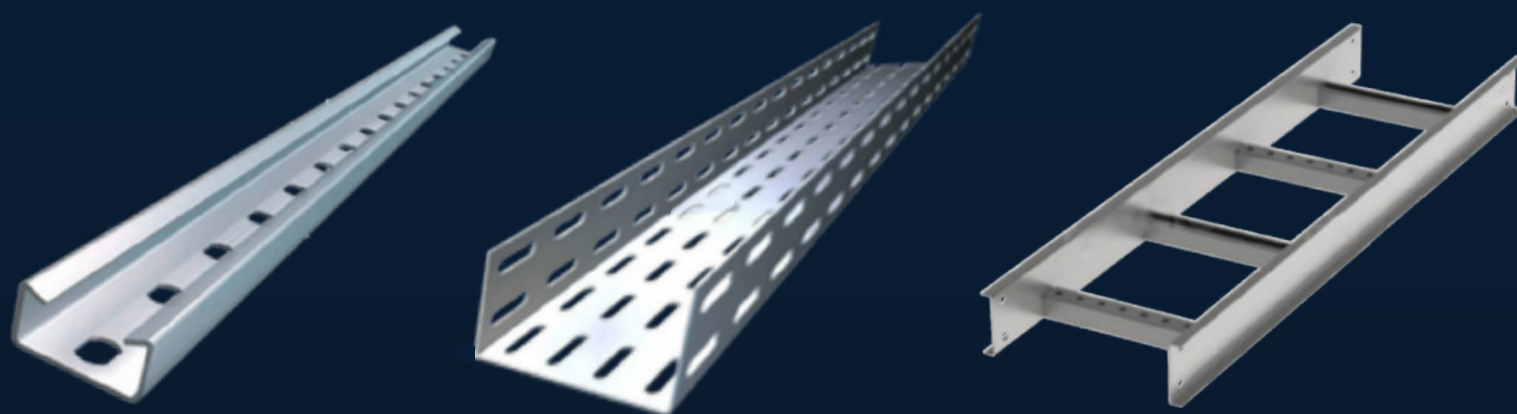

# CANAIS PARA FIOS E CABOS

## CATÁLOGO



Perfilados ... Eletrocalhas ... Leitos para Cabos ... Acessórios de fixação

@rmfindustria

R. Paris, 630 A - Imbiribeira, Recife - PE, 51180-030

Fone / WhatsApp: (81) 3424-6500

[www.rmfre Recife.com.br](http://www.rmfre Recife.com.br)



LEITOS PARA CABOS

TIPO MÉDIO - Ref. RM 40

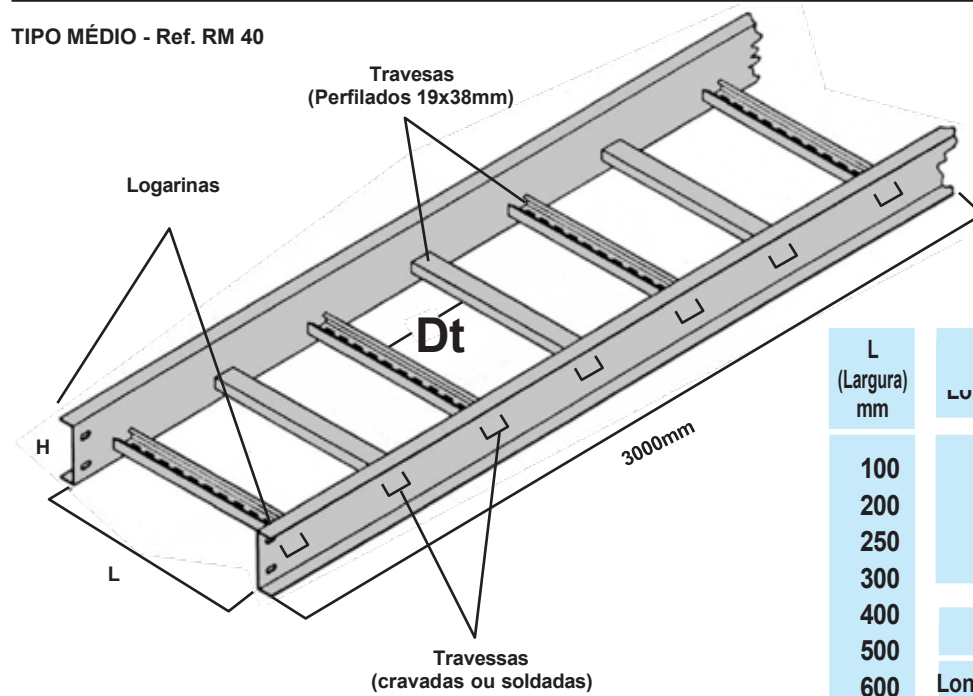

| L<br>(Largura)<br>mm | Longarinas<br>mm | CHAPAS #   |             | Acabamentos |
|----------------------|------------------|------------|-------------|-------------|
|                      |                  | Longarinas | Travesas    |             |
| 100                  | 75               |            |             |             |
| 200                  | 100              |            |             |             |
| 250                  | 150              |            |             |             |
| 300                  | 200              |            |             |             |
| 400                  |                  |            |             |             |
| 500                  |                  |            |             |             |
| 600                  |                  |            |             |             |
| 700                  |                  |            |             |             |
| 800                  | #18              |            | #18         | 1 2 3 5 6   |
| 900                  | #16              |            | #16/#18     | 1 2 3 5 6   |
| 1000                 | #14              |            | #14/#16/#18 | 1 2 3 5 6   |
| 1200                 | #12              |            | #12/#14/#16 | 2 3 6       |

INSTALAÇÃO VERTICAL

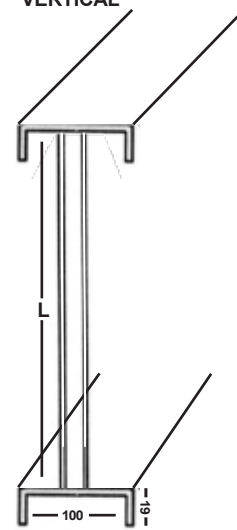

LOGARINAS INVERTIDAS

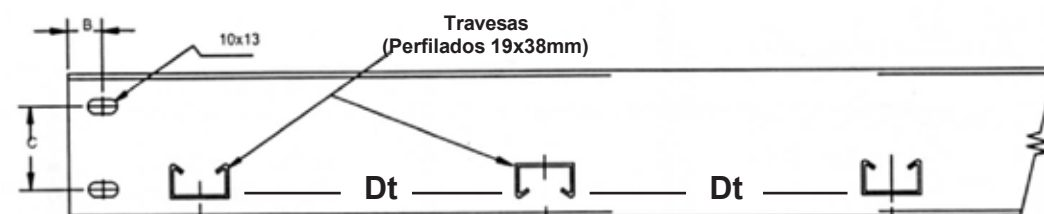
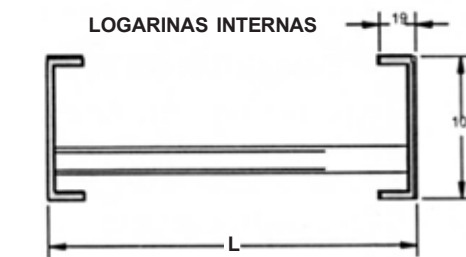
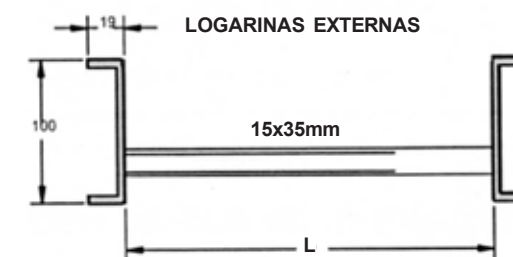
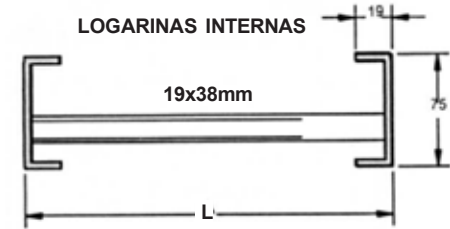
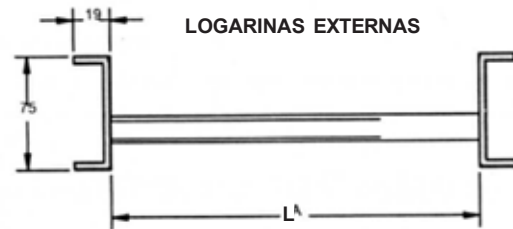

Nota: Não havendo especificação será considerado nosso padrão.



LEITOS PARA CABOS

TIPO PESADO - Ref. RM 42

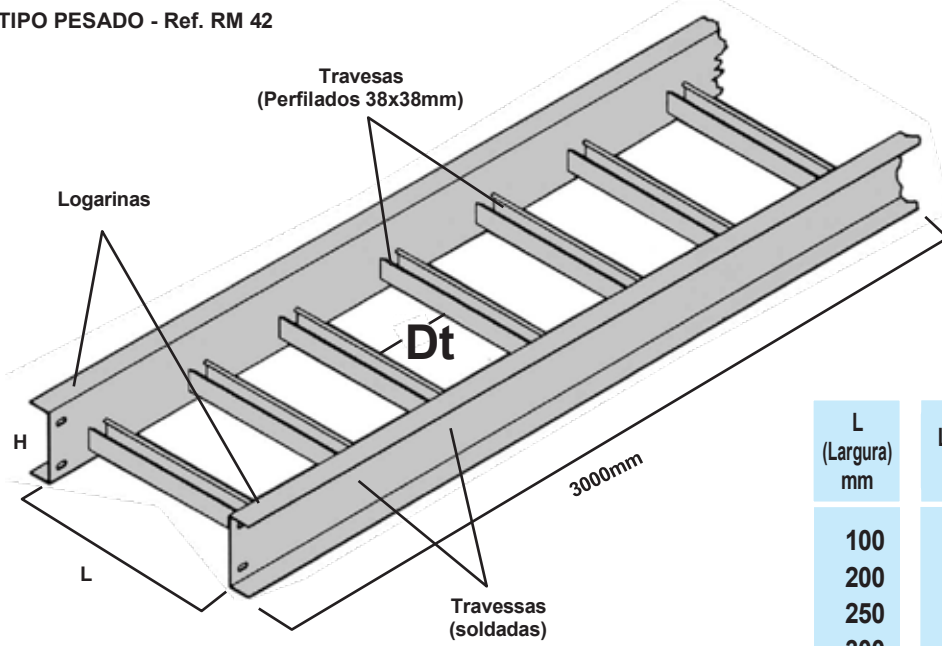

| L (Largura) mm | Longarinas mm | Distância travessas (Dt) mm |             |
|----------------|---------------|-----------------------------|-------------|
| 100            | 75            | 200                         |             |
| 200            | 100           | 250                         |             |
| 250            | 150           | 300                         |             |
| 300            | 200           | 500                         |             |
| 400            | CHAPAS #      |                             |             |
| 500            |               |                             |             |
| 600            | Longarinas    | Travesas                    | Acabamentos |
| 700            |               |                             |             |
| 800            | ≠18           | ≠18                         | 1 2 3 5 6   |
| 900            | ≠16           | ≠16/≠18                     | 1 2 3 5 6   |
| 1000           | ≠14           | ≠14/≠16/≠18                 | 1 2 3 5 6   |
| 1200           | ≠12           | ≠12/≠14/≠16                 | 2 3 6       |

INSTALAÇÃO VERTICAL

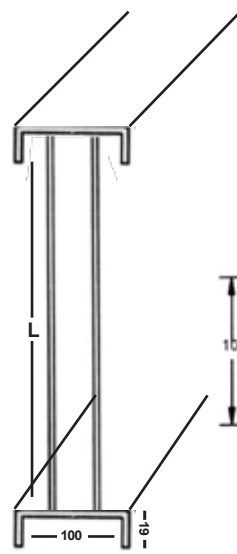

LOGARINAS INVERTIDAS

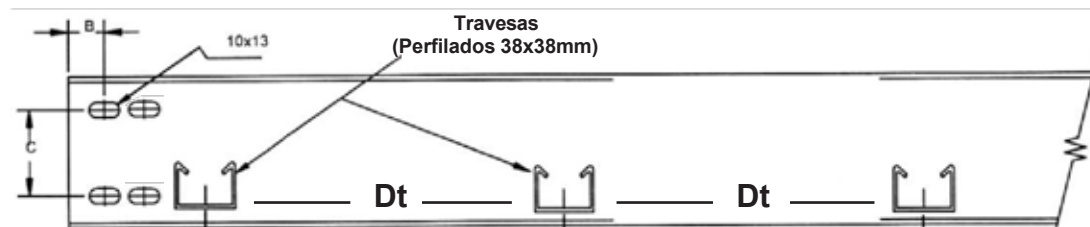
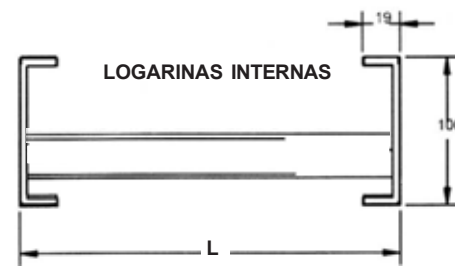
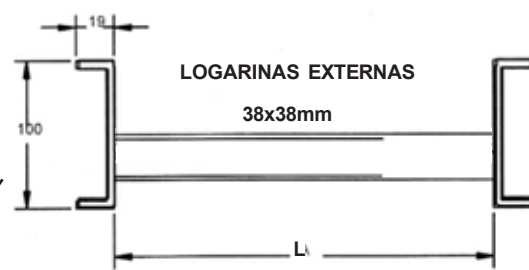

Nota: Não havendo especificação será considerado nosso padrão.



DERIVAÇÕES

CURVA HORIZONTAL 45°

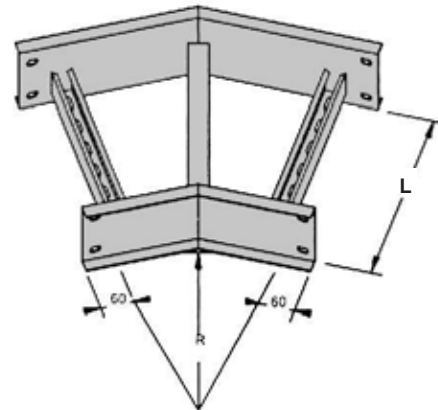

| L<br>Largura<br>(mm) | RAIO SEGMENTADO           |                            |
|----------------------|---------------------------|----------------------------|
|                      | Leito Médio<br>Ref. RM 40 | Leito Pesado<br>Ref. RM 42 |
| 200                  | 320                       | 320<br>*645                |
| 300                  |                           |                            |
| 400                  |                           |                            |
| 500                  |                           |                            |
| 600                  |                           |                            |
| 700                  | 520                       | 520<br>*895                |
| 800                  |                           |                            |
| 900                  |                           |                            |
| 1000                 |                           |                            |
| 1100                 |                           |                            |
| 1200                 |                           |                            |

Ref. 01

CURVA HORIZONTAL 90°

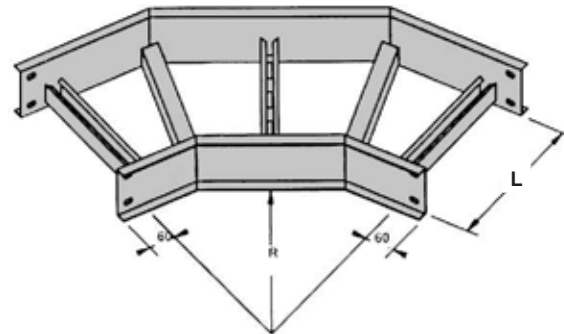

| L<br>Largura<br>(mm) | RAIO SEGMENTADO           |                            |
|----------------------|---------------------------|----------------------------|
|                      | Leito Médio<br>Ref. RM 40 | Leito Pesado<br>Ref. RM 42 |
| 100                  | 320                       | 320<br>*645                |
| 200                  |                           |                            |
| 300                  |                           |                            |
| 400                  |                           |                            |
| 500                  |                           |                            |
| 600                  | 520                       | 520<br>*895                |
| 700                  |                           |                            |
| 800                  |                           |                            |
| 900                  |                           |                            |
| 1000                 |                           |                            |
| 1100                 |                           |                            |
| 1200                 |                           |                            |

Ref. 02

CURVA VERTICAL INTERNA 45°

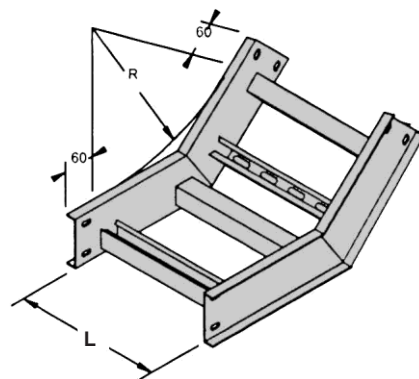

| L<br>Largura<br>(mm) | RAIO SEGMENTADO           |                            |
|----------------------|---------------------------|----------------------------|
|                      | Leito Médio<br>Ref. RM 40 | Leito Pesado<br>Ref. RM 42 |
| 100                  | 320                       | 320<br>*645                |
| 200                  |                           |                            |
| 300                  |                           |                            |
| 400                  |                           |                            |
| 500                  |                           |                            |
| 600                  | 520                       | 520<br>*895                |
| 700                  |                           |                            |
| 800                  |                           |                            |
| 900                  |                           |                            |
| 1000                 |                           |                            |
| 1100                 |                           |                            |
| 1200                 |                           |                            |

Ref. 03

CURVA VERTICAL INTERNA 90°

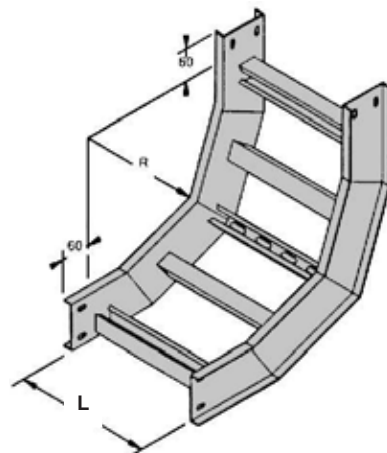

| L<br>Largura<br>(mm) | RAIO SEGMENTADO           |                            |
|----------------------|---------------------------|----------------------------|
|                      | Leito Médio<br>Ref. RM 40 | Leito Pesado<br>Ref. RM 42 |
| 100                  | 320                       | 320<br>*645                |
| 200                  |                           |                            |
| 300                  |                           |                            |
| 400                  |                           |                            |
| 500                  |                           |                            |
| 600                  | 520                       | 520<br>*895                |
| 700                  |                           |                            |
| 800                  |                           |                            |
| 900                  |                           |                            |
| 1000                 |                           |                            |
| 1100                 |                           |                            |
| 1200                 |                           |                            |

Ref. 04

\* SOB CONSULTA



**CURVA VERTICAL EXTERNA 30°**

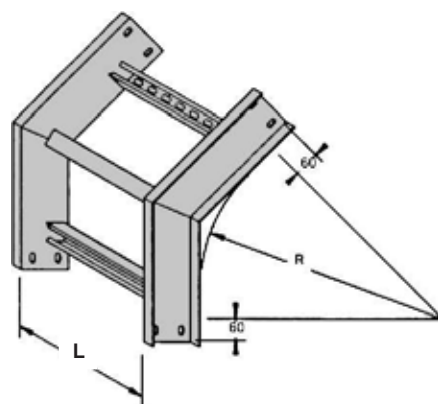

| L<br>Largura<br>(mm) | RAIO SEGMENTADO           |                            |
|----------------------|---------------------------|----------------------------|
|                      | Leito Médio<br>Ref. RM 40 | Leito Pesado<br>Ref. RM 42 |
| 200                  | 320                       | 320<br>*645                |
| 300                  |                           |                            |
| 400                  |                           |                            |
| 500                  |                           |                            |
| 600                  |                           |                            |
| 700                  | 520                       | 520<br>*895                |
| 800                  |                           |                            |
| 900                  |                           |                            |
| 1000                 |                           |                            |
| 1100                 |                           |                            |
| 1200                 |                           |                            |

Ref. 05

**CURVA VERTICAL EXTERNA 90°**

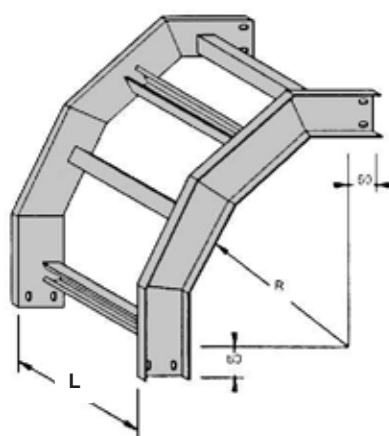

| L<br>Largura<br>(mm) | RAIO SEGMENTADO           |                            |
|----------------------|---------------------------|----------------------------|
|                      | Leito Médio<br>Ref. RM 40 | Leito Pesado<br>Ref. RM 42 |
| 200                  | 320                       | 320<br>*645                |
| 300                  |                           |                            |
| 400                  |                           |                            |
| 500                  |                           |                            |
| 600                  |                           |                            |
| 700                  | 520                       | 520<br>*895                |
| 800                  |                           |                            |
| 900                  |                           |                            |
| 1000                 |                           |                            |
| 1100                 |                           |                            |
| 1200                 |                           |                            |

Ref. 06

**CURVA DE INVERSÃO 90°**

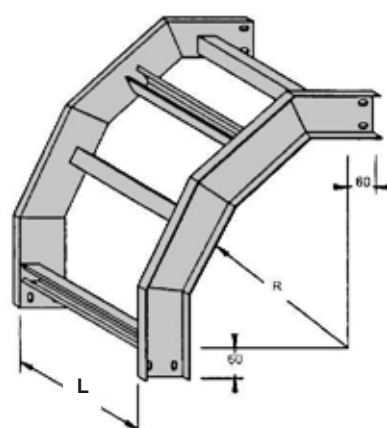

| L<br>Largura<br>(mm) | RAIO SEGMENTADO           |                            |
|----------------------|---------------------------|----------------------------|
|                      | Leito Médio<br>Ref. RM 40 | Leito Pesado<br>Ref. RM 42 |
| 100                  | 320                       | 320<br>*645                |
| 200                  |                           |                            |
| 300                  |                           |                            |
| 400                  |                           |                            |
| 500                  |                           |                            |
| 600                  | 520                       | 520<br>*895                |
| 700                  |                           |                            |
| 800                  |                           |                            |
| 900                  |                           |                            |
| 1000                 |                           |                            |
| 1100                 |                           |                            |
| 1200                 |                           |                            |

Ref. 07

**TÊ HORIZONTAL 90°**

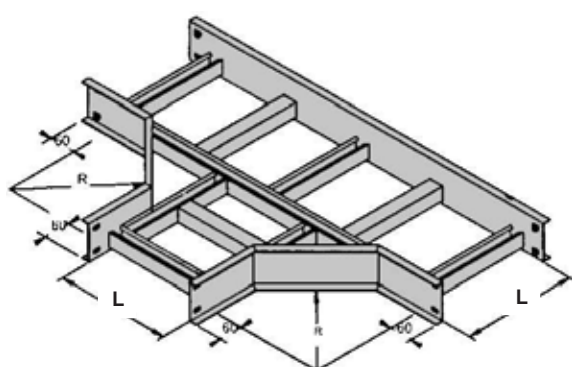

| L<br>Largura<br>(mm) | RAIO SEGMENTADO           |                            |
|----------------------|---------------------------|----------------------------|
|                      | Leito Médio<br>Ref. RM 40 | Leito Pesado<br>Ref. RM 42 |
| 100                  | 320                       | 320<br>*645                |
| 200                  |                           |                            |
| 300                  |                           |                            |
| 400                  |                           |                            |
| 500                  |                           |                            |
| 600                  | 520                       | 520<br>*895                |
| 700                  |                           |                            |
| 800                  |                           |                            |
| 900                  |                           |                            |
| 1000                 |                           |                            |
| 1100                 |                           |                            |
| 1200                 |                           |                            |

Ref. 08

\* SOB CONSULTA



**CRUZETA HORINZONTAL 90°**

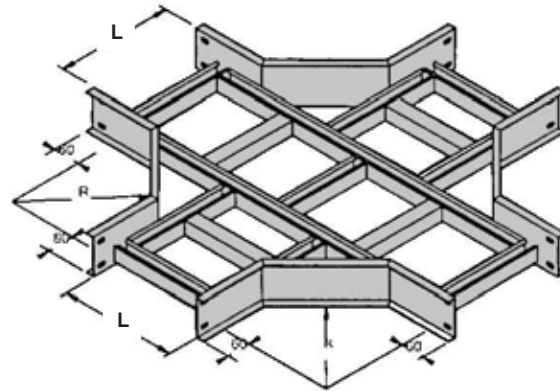

Ref. 09

| L<br>Largura<br>(mm) | RAIO SEGMENTADO           |                            |
|----------------------|---------------------------|----------------------------|
|                      | Leito Médio<br>Ref. RM 40 | Leito Pesado<br>Ref. RM 42 |
| 200                  | 320                       | 320<br>*645                |
| 300                  |                           |                            |
| 400                  |                           |                            |
| 500                  |                           |                            |
| 600                  |                           |                            |
| 700                  | 520                       | 520<br>*895                |
| 800                  |                           |                            |
| 900                  |                           |                            |
| 1000                 |                           |                            |
| 1100                 |                           |                            |
| 1200                 |                           |                            |

**TÊ VERTICAL DE SUBIDA 90°**

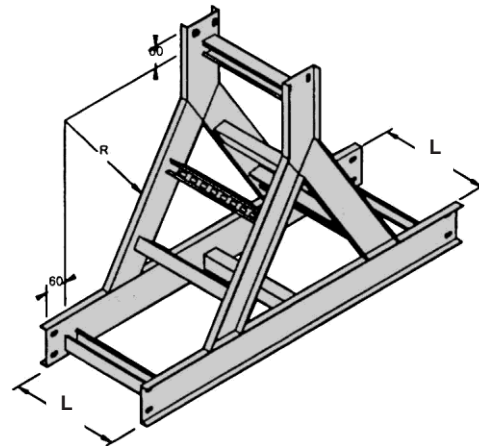

Ref. 10

| L<br>Largura<br>(mm) | RAIO SEGMENTADO           |                            |
|----------------------|---------------------------|----------------------------|
|                      | Leito Médio<br>Ref. RM 40 | Leito Pesado<br>Ref. RM 42 |
| 100                  | 320                       | 320<br>*645                |
| 200                  |                           |                            |
| 300                  |                           |                            |
| 400                  |                           |                            |
| 500                  |                           |                            |
| 600                  | 520                       | 520<br>*895                |
| 700                  |                           |                            |
| 800                  |                           |                            |
| 900                  |                           |                            |
| 1000                 |                           |                            |
| 1100                 |                           |                            |
| 1200                 |                           |                            |

**TÊ VERTICAL DESCIDA 90°**

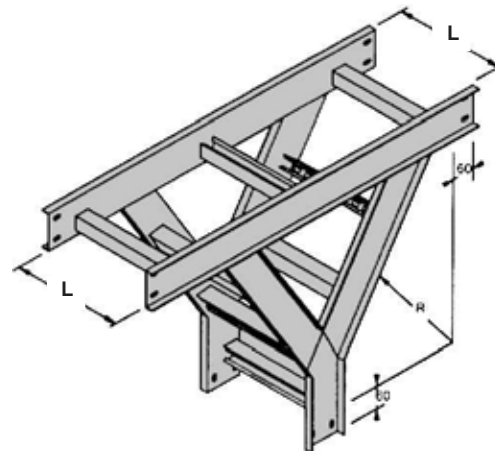

Ref. 11

| L<br>Largura<br>(mm) | RAIO SEGMENTADO           |                            |
|----------------------|---------------------------|----------------------------|
|                      | Leito Médio<br>Ref. RM 40 | Leito Pesado<br>Ref. RM 42 |
| 100                  | 320                       | 320<br>*645                |
| 200                  |                           |                            |
| 300                  |                           |                            |
| 400                  |                           |                            |
| 500                  |                           |                            |
| 600                  | 520                       | 520<br>*895                |
| 700                  |                           |                            |
| 800                  |                           |                            |
| 900                  |                           |                            |
| 1000                 |                           |                            |
| 1100                 |                           |                            |
| 1200                 |                           |                            |

**COTOVELO RETO 90°**

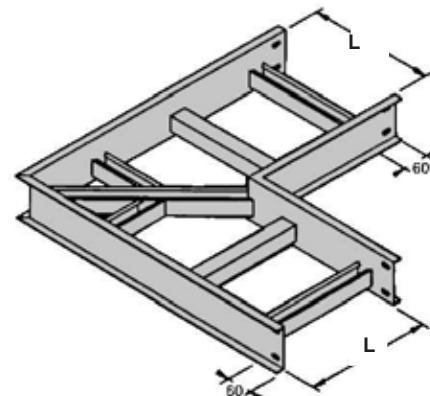

Ref. 12

| L<br>Largura<br>(mm) | RAIO SEGMENTADO           |                            |
|----------------------|---------------------------|----------------------------|
|                      | Leito Médio<br>Ref. RM 40 | Leito Pesado<br>Ref. RM 42 |
| 100                  | 320                       | 320<br>*645                |
| 200                  |                           |                            |
| 300                  |                           |                            |
| 400                  |                           |                            |
| 500                  |                           |                            |
| 600                  | 520                       | 520<br>*895                |
| 700                  |                           |                            |
| 800                  |                           |                            |
| 900                  |                           |                            |
| 1000                 |                           |                            |
| 1100                 |                           |                            |
| 1200                 |                           |                            |

\* SOB CONSULTA



**TÊ VERTICAL DE DERIVAÇÃO 90°**

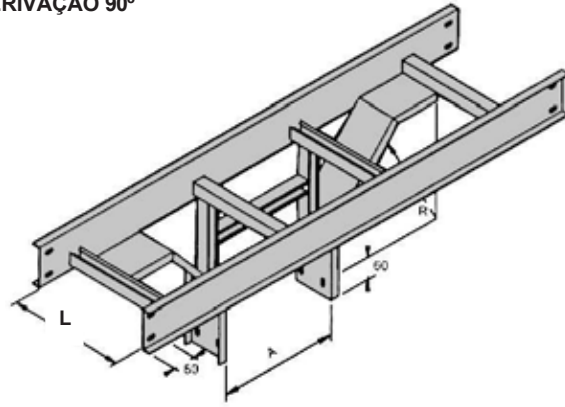

Ref. 13

| L<br>Largura<br>(mm) | RAIO SEGMENTADO           |                            |
|----------------------|---------------------------|----------------------------|
|                      | Leito Médio<br>Ref. RM 40 | Leito Pesado<br>Ref. RM 42 |
| 100                  | 320                       | 320<br>*645                |
| 200                  |                           |                            |
| 300                  |                           |                            |
| 400                  |                           |                            |
| 500                  |                           |                            |
| 600                  | 520                       | 520<br>*895                |
| 700                  |                           |                            |
| 800                  |                           |                            |
| 900                  |                           |                            |
| 1000                 |                           |                            |
| 1100                 |                           |                            |
| 1200                 |                           |                            |

**JUNÇÃO DIREITA 45°**

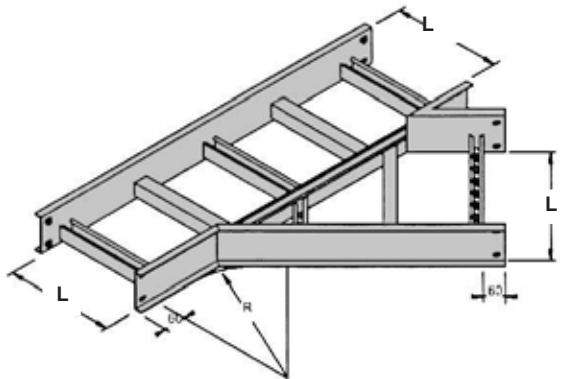

Ref. 14

| L<br>Largura<br>(mm) | RAIO SEGMENTADO           |                            |
|----------------------|---------------------------|----------------------------|
|                      | Leito Médio<br>Ref. RM 40 | Leito Pesado<br>Ref. RM 42 |
| 100                  | 320                       | 320<br>*645                |
| 200                  |                           |                            |
| 300                  |                           |                            |
| 400                  |                           |                            |
| 500                  |                           |                            |
| 600                  | 520                       | 520<br>*895                |
| 700                  |                           |                            |
| 800                  |                           |                            |
| 900                  |                           |                            |
| 1000                 |                           |                            |
| 1100                 |                           |                            |
| 1200                 |                           |                            |

**JUNÇÃO ESQUERDA 45°**

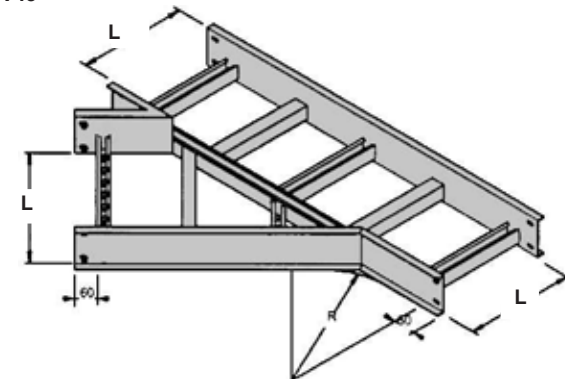

Ref. 15

| L<br>Largura<br>(mm) | RAIO SEGMENTADO           |                            |
|----------------------|---------------------------|----------------------------|
|                      | Leito Médio<br>Ref. RM 40 | Leito Pesado<br>Ref. RM 42 |
| 100                  | 320                       | 320<br>*645                |
| 200                  |                           |                            |
| 300                  |                           |                            |
| 400                  |                           |                            |
| 500                  |                           |                            |
| 600                  | 520                       | 520<br>*895                |
| 700                  |                           |                            |
| 800                  |                           |                            |
| 900                  |                           |                            |
| 1000                 |                           |                            |
| 1100                 |                           |                            |
| 1200                 |                           |                            |

**CRUZETA COM SAÍDA RETA 90°**

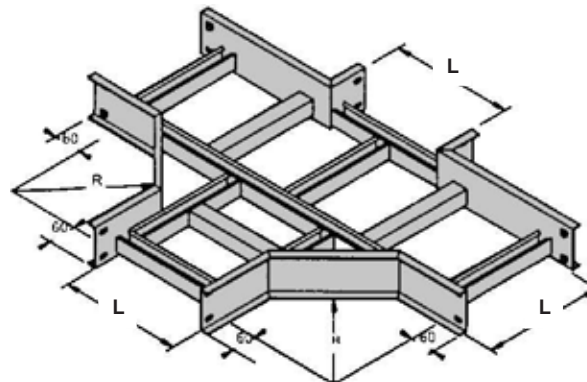

Ref. 16

| L<br>Largura<br>(mm) | RAIO SEGMENTADO           |                            |
|----------------------|---------------------------|----------------------------|
|                      | Leito Médio<br>Ref. RM 40 | Leito Pesado<br>Ref. RM 42 |
| 100                  | 320                       | 320<br>*645                |
| 200                  |                           |                            |
| 300                  |                           |                            |
| 400                  |                           |                            |
| 500                  |                           |                            |
| 600                  | 520                       | 520<br>*895                |
| 700                  |                           |                            |
| 800                  |                           |                            |
| 900                  |                           |                            |
| 1000                 |                           |                            |
| 1100                 |                           |                            |
| 1200                 |                           |                            |

\* SOB CONSULTA



**CURVA COM PASSAGEM RETA SUBIDA 90°**

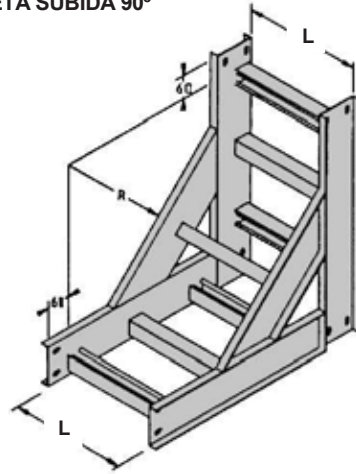

| L<br>Largura<br>(mm) | RAIO SEGMENTADO           |                            |
|----------------------|---------------------------|----------------------------|
|                      | Leito Médio<br>Ref. RM 40 | Leito Pesado<br>Ref. RM 42 |
| 100                  | 320                       | 320                        |
| 200                  |                           |                            |
| 300                  |                           |                            |
| 400                  |                           |                            |
| 500                  |                           |                            |
| 600                  |                           |                            |
| 700                  | 520                       | 520                        |
| 800                  |                           |                            |
| 900                  |                           |                            |
| 1000                 |                           |                            |
| 1100                 |                           |                            |
| 1200                 |                           |                            |

Ref. 17

**CURVA COM PASSAGEM RETA DESCIDA 90°**

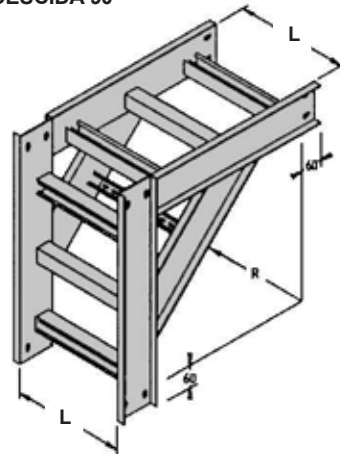

| L<br>Largura<br>(mm) | RAIO SEGMENTADO           |                            |
|----------------------|---------------------------|----------------------------|
|                      | Leito Médio<br>Ref. RM 40 | Leito Pesado<br>Ref. RM 42 |
| 100                  | 320                       | 320                        |
| 200                  |                           |                            |
| 300                  |                           |                            |
| 400                  |                           |                            |
| 500                  |                           |                            |
| 600                  |                           |                            |
| 700                  | 520                       | 520                        |
| 800                  |                           |                            |
| 900                  |                           |                            |
| 1000                 |                           |                            |
| 1100                 |                           |                            |
| 1200                 |                           |                            |

Ref. 18

**JUNÇÃO ESQUERDA 90°**

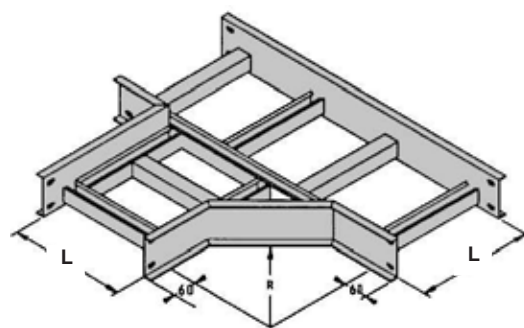

| L<br>Largura<br>(mm) | RAIO SEGMENTADO           |                            |
|----------------------|---------------------------|----------------------------|
|                      | Leito Médio<br>Ref. RM 40 | Leito Pesado<br>Ref. RM 42 |
| 100                  | 320                       | 320                        |
| 200                  |                           |                            |
| 300                  |                           |                            |
| 400                  |                           |                            |
| 500                  |                           |                            |
| 600                  |                           |                            |
| 700                  | 520                       | 520                        |
| 800                  |                           |                            |
| 900                  |                           |                            |
| 1000                 |                           |                            |
| 1100                 |                           |                            |
| 1200                 |                           |                            |

Ref. 19

**REDUÇÃO CONCÊNTRICA**

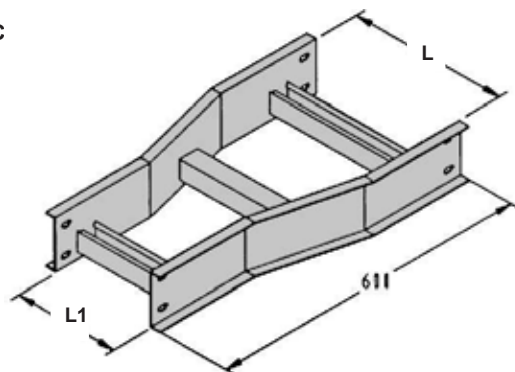

| L<br>Largura<br>(mm) | RAIO SEGMENTADO           |                            |
|----------------------|---------------------------|----------------------------|
|                      | Leito Médio<br>Ref. RM 40 | Leito Pesado<br>Ref. RM 42 |
| 200                  | 320                       | 320                        |
| 300                  |                           |                            |
| 400                  |                           |                            |
| 500                  |                           |                            |
| 600                  |                           |                            |
| 700                  |                           |                            |
| 800                  | 520                       | 520                        |
| 900                  |                           |                            |
| 1000                 |                           |                            |
| 1100                 |                           |                            |
| 1200                 |                           |                            |
|                      |                           |                            |

Ref. 20

\* SOB CONSULTA

**TÊ RETO 90°**

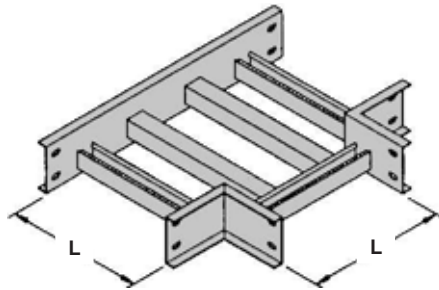

Ref. 21

| L<br>Largura<br>(mm) | RAIO SEGMENTADO           |                            |
|----------------------|---------------------------|----------------------------|
|                      | Leito Médio<br>Ref. RM 40 | Leito Pesado<br>Ref. RM 42 |
| 200                  | 320                       | 320<br>*645                |
| 300                  |                           |                            |
| 400                  |                           |                            |
| 500                  |                           |                            |
| 600                  |                           |                            |
| 700                  | 520                       | 520<br>*895                |
| 800                  |                           |                            |
| 900                  |                           |                            |
| 1000                 |                           |                            |
| 1100                 |                           |                            |
| 1200                 |                           |                            |

**CRUZETA RETA 90°**

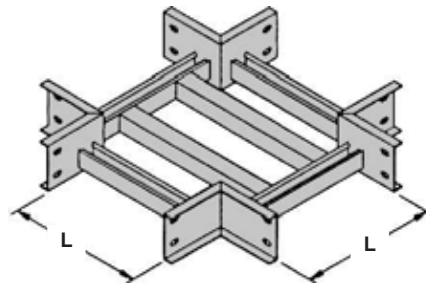

Ref. 22

| L<br>Largura<br>(mm) | RAIO SEGMENTADO           |                            |
|----------------------|---------------------------|----------------------------|
|                      | Leito Médio<br>Ref. RM 40 | Leito Pesado<br>Ref. RM 42 |
| 200                  | 320                       | 320<br>*645                |
| 300                  |                           |                            |
| 400                  |                           |                            |
| 500                  |                           |                            |
| 600                  |                           |                            |
| 700                  | 520                       | 520<br>*895                |
| 800                  |                           |                            |
| 900                  |                           |                            |
| 1000                 |                           |                            |
| 1100                 |                           |                            |
| 1200                 |                           |                            |

**JUNÇÃO DIREITA 90°**

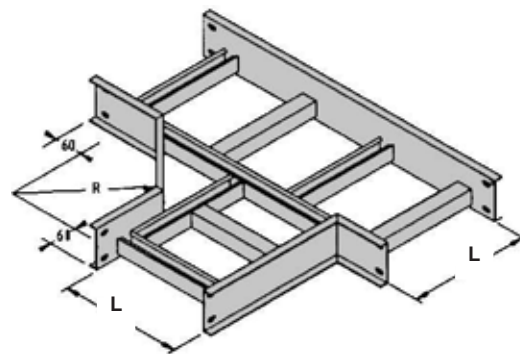

Ref. 23

| L<br>Largura<br>(mm) | RAIO SEGMENTADO           |                            |
|----------------------|---------------------------|----------------------------|
|                      | Leito Médio<br>Ref. RM 40 | Leito Pesado<br>Ref. RM 42 |
| 100                  | 320                       | 320<br>*645                |
| 200                  |                           |                            |
| 300                  |                           |                            |
| 400                  |                           |                            |
| 500                  |                           |                            |
| 600                  | 520                       | 520<br>*895                |
| 700                  |                           |                            |
| 800                  |                           |                            |
| 900                  |                           |                            |
| 1000                 |                           |                            |
| 1100                 |                           |                            |
| 1200                 |                           |                            |

**REDUÇÃO RETA CONCÊNTRICA**

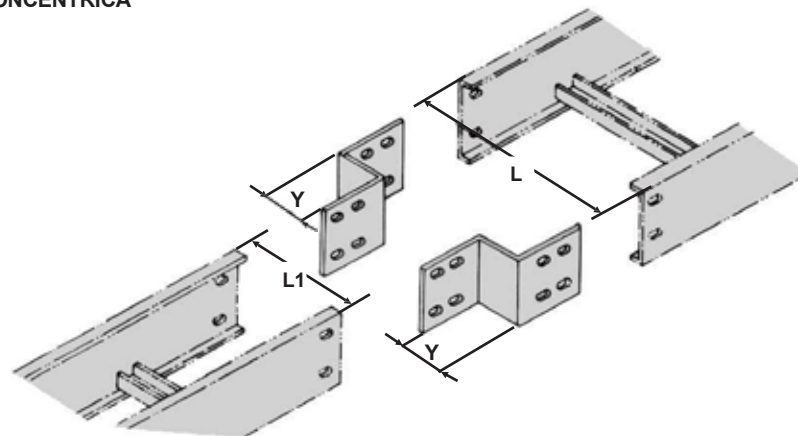

$$(\text{Dimen. Y}) = \frac{(\text{Dimen. L}) - (\text{Dimen. L1})}{2}$$

ESPECIFICAR "Y" NA REFERÊNCIA

Ref. 24

\* SOB CONSULTA



**REDUÇÃO ESQUERDA**

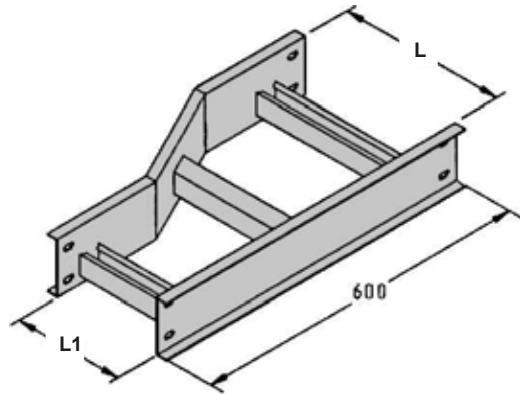

| L<br>Largura<br>(mm) | RAIO SEGMENTADO           |                            |
|----------------------|---------------------------|----------------------------|
|                      | Leito Médio<br>Ref. RM 40 | Leito Pesado<br>Ref. RM 42 |
| 200                  | 320                       | 320<br>*645                |
| 300                  |                           |                            |
| 400                  |                           |                            |
| 500                  |                           |                            |
| 600                  |                           |                            |
| 700                  | 520                       | 520<br>*895                |
| 800                  |                           |                            |
| 900                  |                           |                            |
| 1000                 |                           |                            |
| 1100                 |                           |                            |
| 1200                 |                           |                            |

Ref. 25

**REDUÇÃO DIREITA**

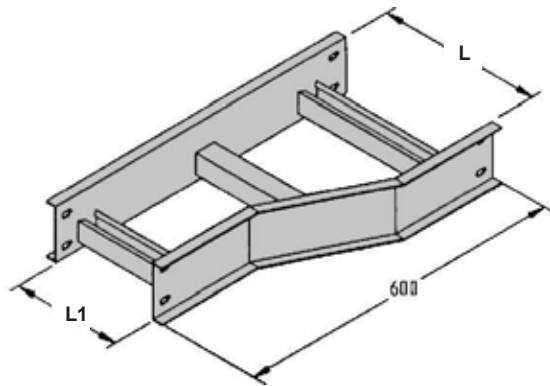

| L<br>Largura<br>(mm) | RAIO SEGMENTADO           |                            |
|----------------------|---------------------------|----------------------------|
|                      | Leito Médio<br>Ref. RM 40 | Leito Pesado<br>Ref. RM 42 |
| 200                  | 320                       | 320<br>*645                |
| 300                  |                           |                            |
| 400                  |                           |                            |
| 500                  |                           |                            |
| 600                  |                           |                            |
| 700                  | 520                       | 520<br>*895                |
| 800                  |                           |                            |
| 900                  |                           |                            |
| 1000                 |                           |                            |
| 1100                 |                           |                            |
| 1200                 |                           |                            |

Ref. 26

\* SOB CONSULTA

**REDUÇÃO RETA EXCÊNTRICA**

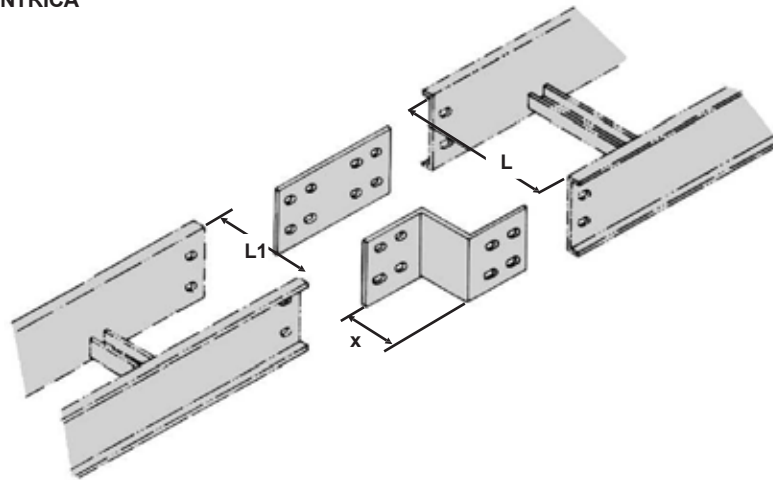

Ref. 27

**TERMINAL**

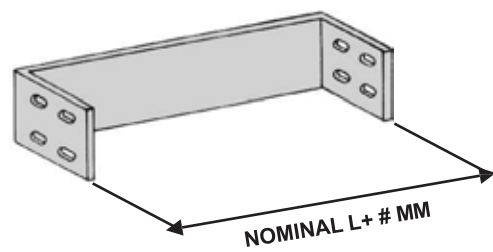

| Leito Médio<br>Ref. RM 40 |     |     |      | Leito Pesado<br>Ref. RM 42 |      |
|---------------------------|-----|-----|------|----------------------------|------|
| A                         | 100 | 500 | 800  | A                          | 250  |
|                           | 200 | 600 | 1000 |                            | 500  |
|                           | 300 | 700 | 1200 |                            | 750  |
|                           | 400 |     |      |                            | 1000 |
|                           |     |     |      |                            | 1230 |
|                           |     |     |      |                            | 1500 |

Ref. 28

PROTEÇÃO PARA LIG. EM PAINÉL

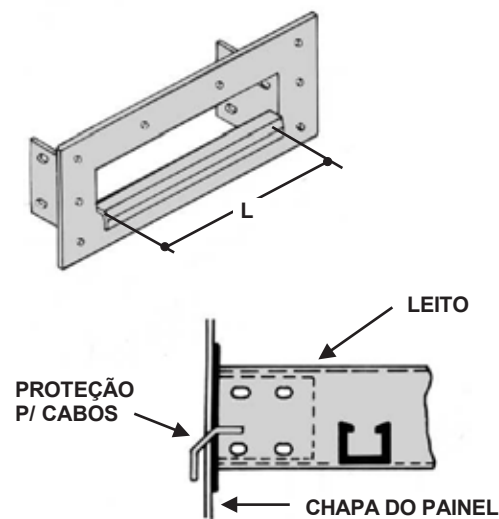

| L    | H   |
|------|-----|
| 100  | 375 |
| 200  | 100 |
| 300  | 150 |
| 400  | 200 |
| 500  |     |
| 600  |     |
| 700  |     |
| 800  |     |
| 1000 |     |
| 1200 |     |

Ref. 29

CURVA VERTICAL ARTICULADA

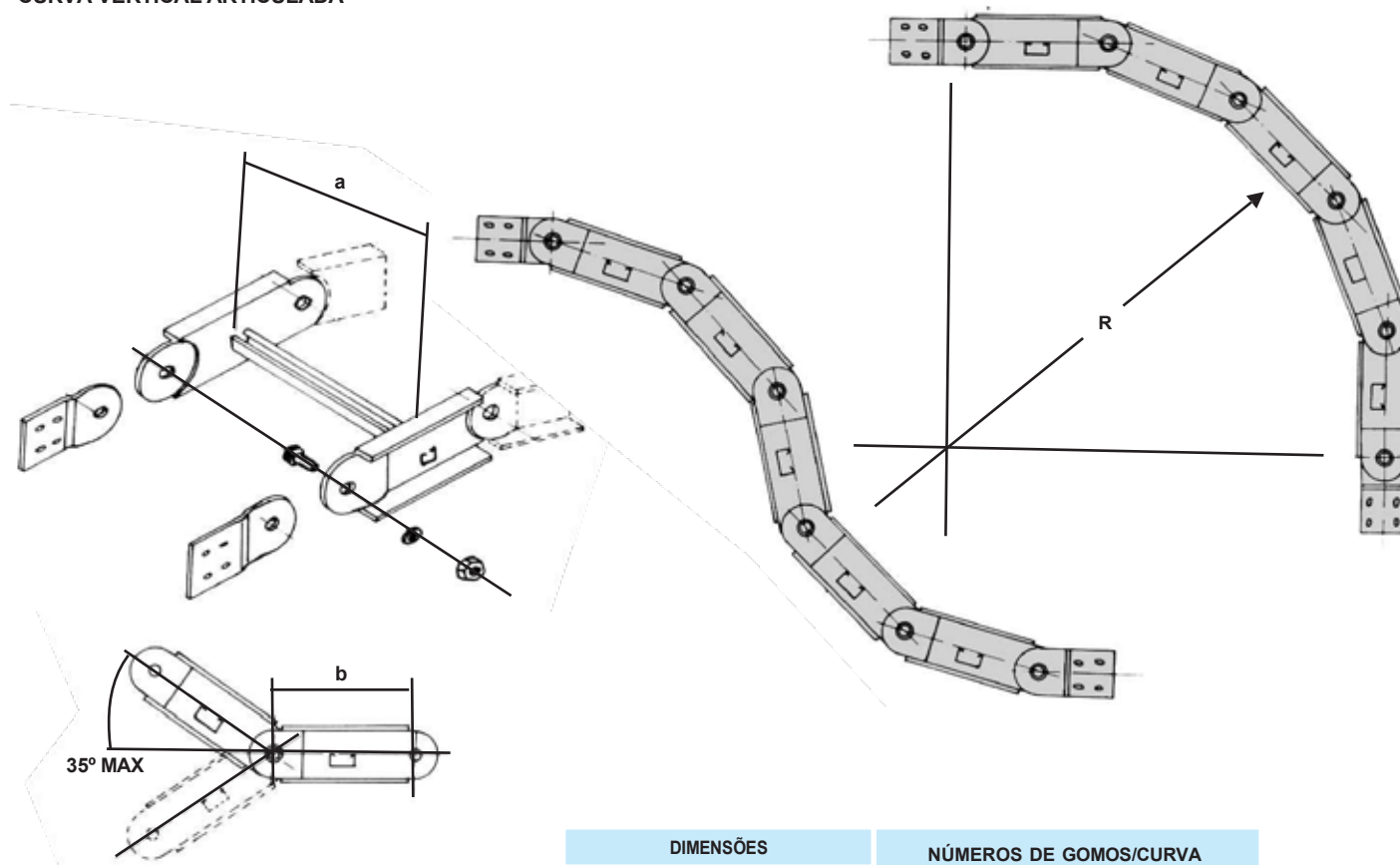

| DIMENSÕES                 |     |                            |     | NÚMEROS DE GOMOS/CURVA |                           |       |                            |       |   |  |
|---------------------------|-----|----------------------------|-----|------------------------|---------------------------|-------|----------------------------|-------|---|--|
| P/REFERÊNCIA              |     |                            |     | GRAUS                  | P/REFERÊNCIA              |       |                            |       |   |  |
| Leito Médio<br>Ref. RM 40 |     | Leito Pesado<br>Ref. RM 42 |     |                        | Leito Médio<br>Ref. RM 40 |       | Leito Pesado<br>Ref. RM 42 |       |   |  |
| A                         | B   | A                          | B   |                        | R-320                     | R-520 | R-645                      | R-895 |   |  |
| 100                       | 140 | 250                        | 250 | 15°                    | -                         | 1     | -                          | 1     |   |  |
| 200                       |     |                            |     | 22°                    | 1                         | -     | 1                          | -     |   |  |
| 300                       |     |                            |     | 30°                    | -                         | 2     | -                          | 2     | - |  |
| 400                       |     |                            |     | 45°                    | -                         | 3     | -                          | 2     | 3 |  |
| 500                       |     |                            |     | 60°                    | -                         | 5     | -                          | 4     | - |  |
| 600                       |     |                            |     | 67°                    | -                         | 3     | -                          | 3     | - |  |
| 700                       |     |                            |     | 75°                    | -                         | 5     | -                          | 5     | - |  |
| 800                       |     |                            |     | 90°                    | -                         | 4     | 6                          | 4     | 6 |  |
| 1000                      |     |                            |     |                        |                           |       |                            |       |   |  |
| 1200                      |     |                            |     |                        |                           |       |                            |       |   |  |

Ref. 30



**TAMPAS**

**TAMPA DE ENCAIXE**

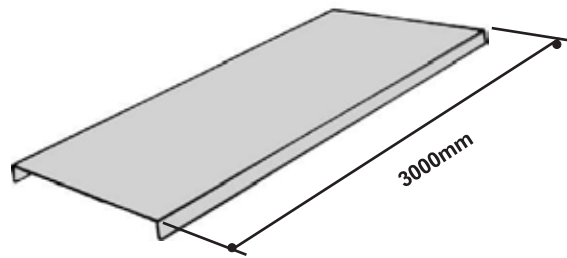

Ref. 31

**TAMPA 2 ÁGUAS**

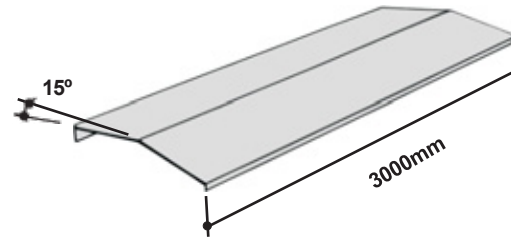

Ref. 32

**DEMOSTRATIVO DE MONTAGEM**

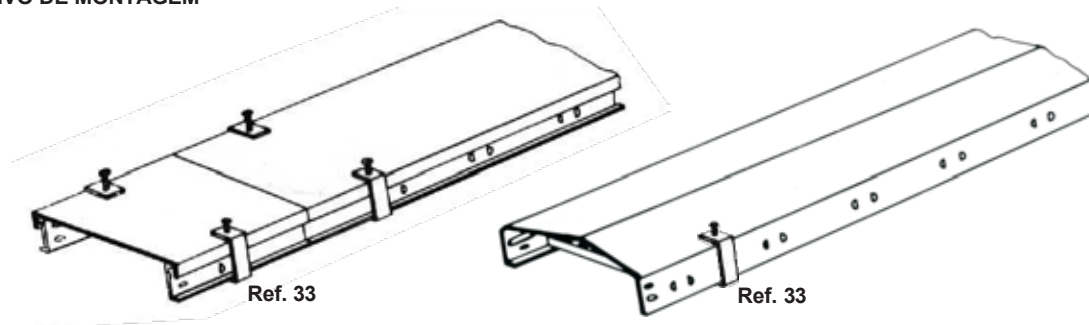

NOTA: PARA SOLICITAÇÃO DAS TAMPAS, ACRESCENTAR O CÓDIGO ANTERIOR À REFERÊNCIA DO LEITO OU DERIVAÇÃO CORRENPDENTE.

**PRESILHA PARA TAMPA DE ENCAIXE**  
ANCHOR CLIP FOR INSERTING COVER

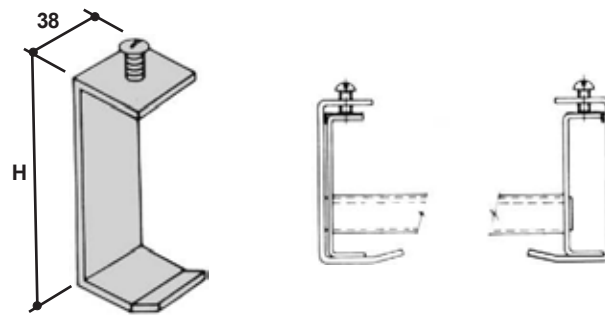

Ref. 33

**ACESSÓRIOS**

**JUNÇÃO SIMPLES**



TABELA DE FIXAÇÃO DAS TALAS

| H (Logarinas) | Parafusos, Porcas e Arruelas |
|---------------|------------------------------|
| 75 mm         | 04 conjuntos                 |
| 100 mm        | 08 conjuntos                 |
| 150 mm        | 12 conjuntos                 |
| 200 mm        | 16 conjuntos                 |

PARAFUSO RECOMENDADO PARA JUNÇÃO:  
CAB. LENTILHA AT 5/16" X 1/2" C/PORÇA SEXT. E ARRUELA.  
OUTRAS MEDIDAS CONSULTAR PAG. 09.

Ref. 34

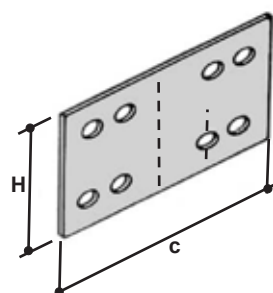

### JUNÇÃO RETA

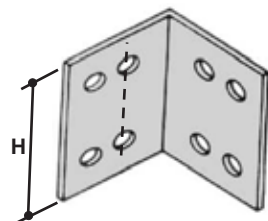

H (Logarinas)

75 mm  
100 mm  
150 mm  
200 mm

PARAFUSO RECOMENDADO PARA JUNÇÃO:  
CAB. LENTILHA AT 5/16" X 1/2" C/PORCA SEXT. E ARRUELA.  
OUTRAS MEDIDAS CONSULTAR PAG. 09.

Ref. 35

### JUNÇÃO ARTICULADA

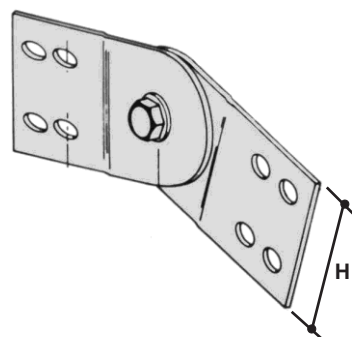

H (Logarinas)

75 mm  
100 mm  
150 mm  
200 mm

PARAFUSO RECOMENDADO PARA JUNÇÃO:  
CAB. LENTILHA AT 5/16" X 1/2" C/PORCA SEXT. E ARRUELA.  
OUTRAS MEDIDAS CONSULTAR PAG. 09.

Ref. 36

### GRAPA

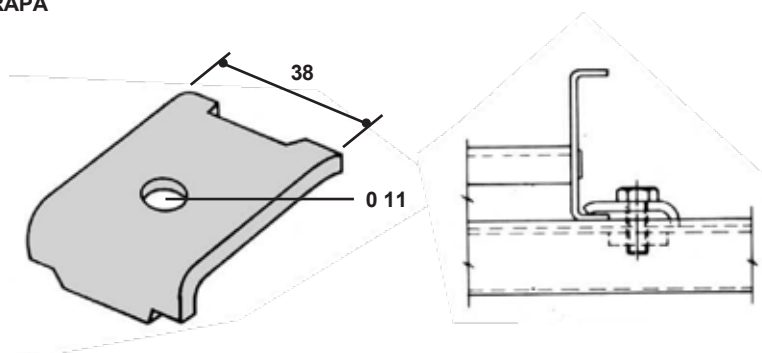

NOTA: FIXA RIGIDAMENTE O LEITO NO SENTIDO  
TRANSVERSAL E LONGITUDINAL.

Ref. 37

### PRESILHA GUIA

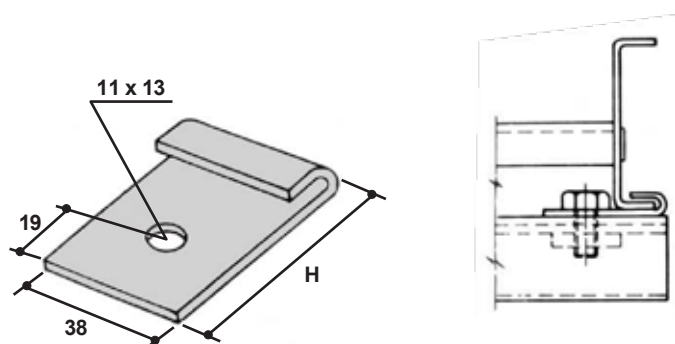

H

91

NOTA: FIXA RIGIDAMENTE O LEITO NO SENTIDO  
TRANSVERSAL E LONGITUDINAL.

Ref. 38



SUPOORTE SIMPLES

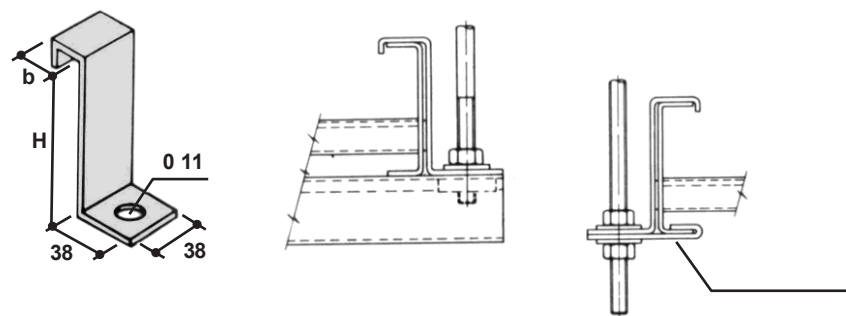

| H  | B  |
|----|----|
| 75 | 22 |
| 97 | 22 |

Ref. 39

SUPOORTE DE SUSPENSÃO

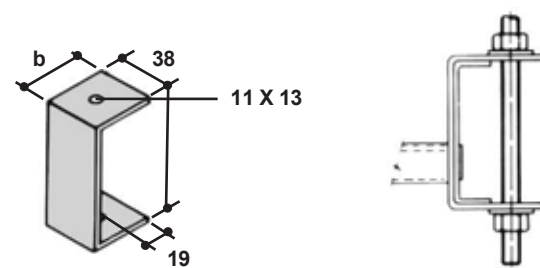

| H   | B  |
|-----|----|
| 77  | 51 |
| 102 | 51 |

Ref. 40

SUPOORTE DE FIXAÇÃO LATERAL

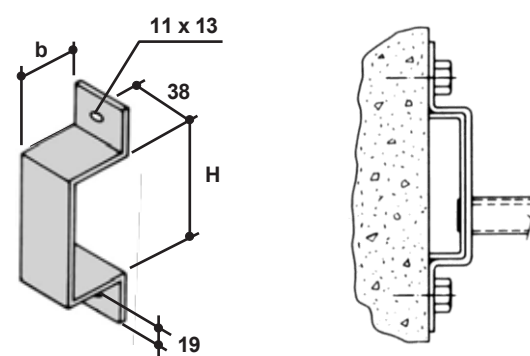

| H   | b  |
|-----|----|
| 77  | 16 |
| 102 | 16 |

Ref. 41

DIVISOR

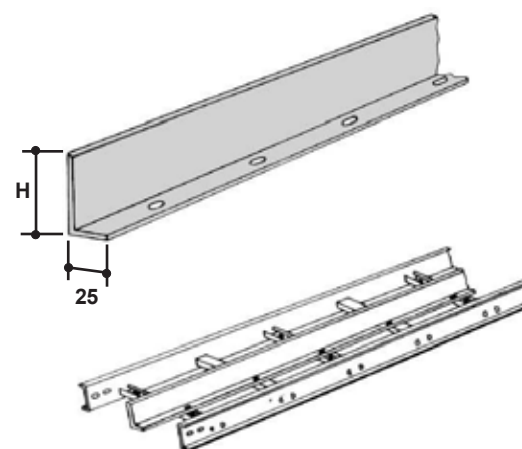

| LEITO  | LOGARINAS | H  |
|--------|-----------|----|
| MÉDIA  | 45        | 50 |
| MÉDIA  | 100       | 75 |
| PESADA | 100       | 55 |

Ref. 42

SAÍDA HORIZONTAL PARA ELETRODUTO

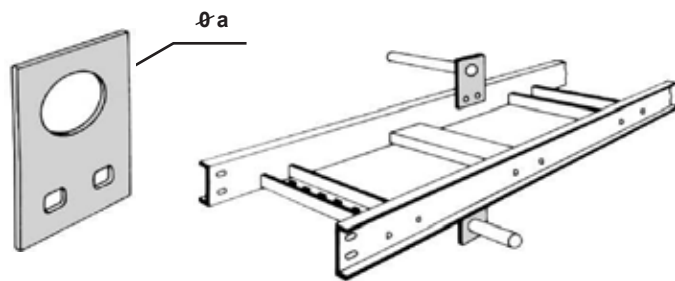

OBS.: Consultar pag. 20

SAÍDA VERTICAL PARA ELETRODUTO

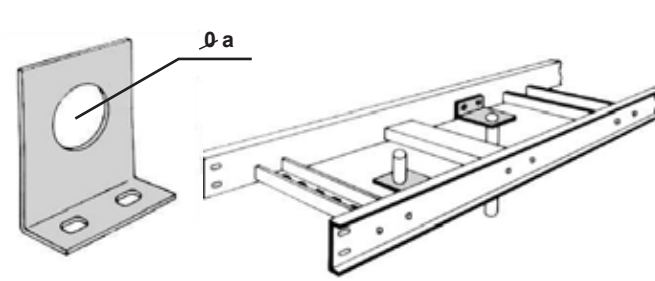

OBS.: Consultar pag. 20

SAÍDA HORIZONTAL PARA PERFILADO

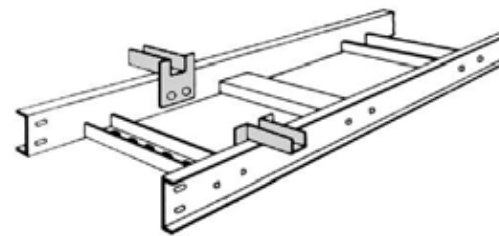
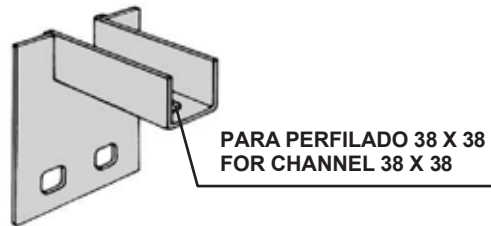

Ref. 30.51

LEITO ARAMADO (SANITÁRIO)

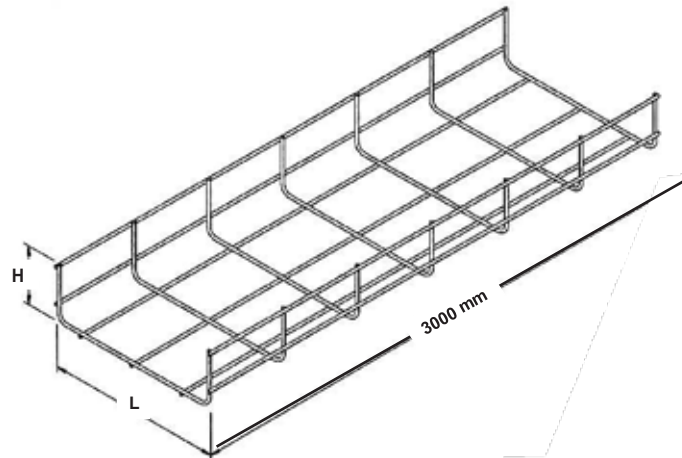

| L \ H | 50     | 65     | 100     |
|-------|--------|--------|---------|
| 50    | 50/50  | 50/65  | 50/100  |
| 75    | 75/50  | 75/65  | 75/100  |
| 100   | 100/50 | 100/65 | 100/100 |
| 150   | 150/50 | 150/65 | 150/100 |
| 200   | 200/50 | 200/65 | 200/100 |
| 300   | 300/50 | 300/65 | 300/100 |
| 400   | 400/50 | 400/65 | 400/100 |
| 500   | 500/50 | 500/65 | 500/100 |

Ref. RM 50

CURVA HORIZONTAL 45°

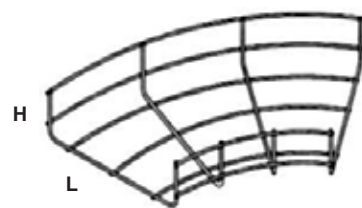

Ref. RM 50.1

CURVA HORIZONTAL 90°

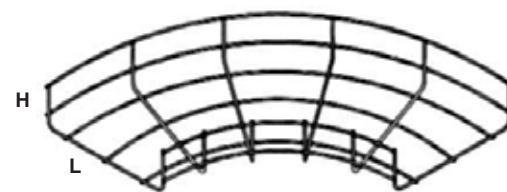

Ref. RM 50.2

CURVA VERTICAL EXTERNA 45°

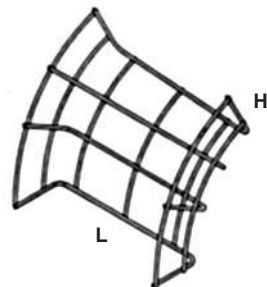

Ref. RM 50.3

CURVA VERTICAL EXTERNA 90°

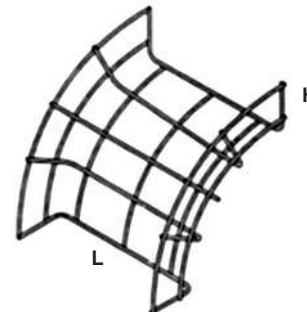

Ref. RM 50.4



CURVA VERTICAL INTERNA 45°

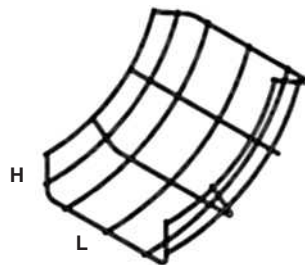

Ref. RM 50.5

CURVA VERTICAL INTERNA 90°

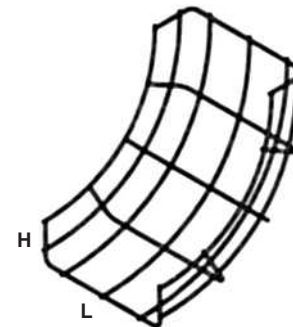

Ref. RM 50.6

TÊ HORIZONTAL 90°

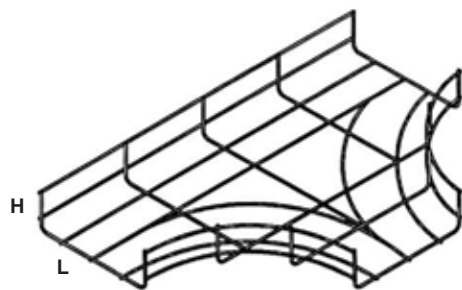

Ref. RM 50.7

CRUZETA HORIZONTAL 90°

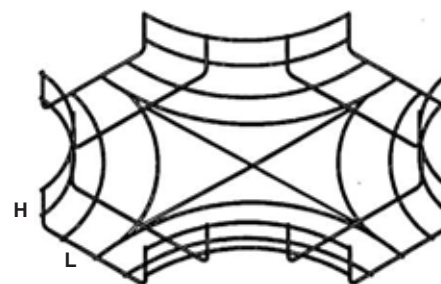

Ref. RM 50.8

REDUÇÃO DIREITA

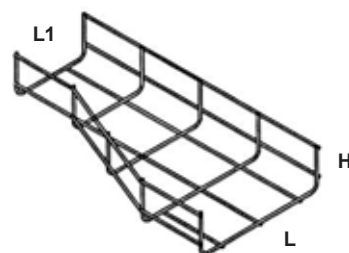

Ref. RM 50.11

REDUÇÃO CONCÊNTRICA

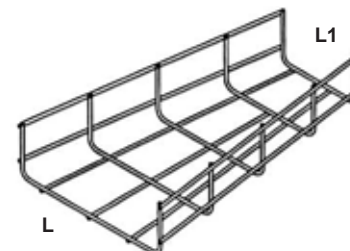

Ref. RM 50.9

REDUÇÃO ESQUERDA

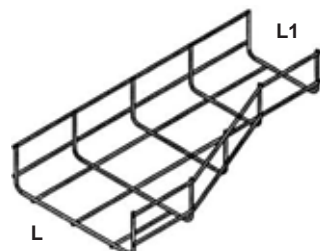

Ref. RM 50.10

CONECTOR PATA EMENDA

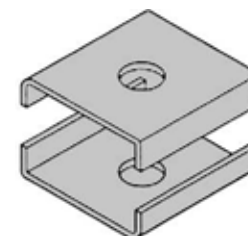

OBS.: PARAFUSO CABEÇA REDONDA DE 1/4x1/2, PORCAS E ARRUELAS